

# Peripheral Hot Stamping & Heat Transfer Equipment



## For Decorating Cylindrical Parts up to 360°

machines provide advanced capabilities for reduced setup time, high reliability, efficiency, smooth and quiet operation and simplified troubleshooting. All machines feature stable, consistent head travel and smooth heat transfer advance for optimum quality from job-to-job.

### Advanced Control System

- Job storage capabilities
- Advanced diagnostic
- Digital control of temperature and time parameters
- Touch Screen HMI

### Stable Head Control

- Head guide system for accurate positioning throughout the head stroke
- Safe, quiet, smooth cycling
- Convenient, accurate stroke length adjustment for rapid setup
- Front panel speed controls to set ideal head travel speeds, stamping pressure, and heat transfer stripping condition

### Precision Heat Transfer Web Advance

- Motorized Unwind and Rewind of the Web for Improved Tension Control during the Decorating Process
- Electronic web offset adjustment
- Accurate, repeatable transfer placement

United Silicone, part of Industrial Decorating Solutions (IDS), specializes in the design and production of standard and custom hot stamp and heat transfer decorating machines. Our automation department offers complete capabilities from integrated applications to full turnkey systems.

United Silicone also provides a complete range of supplies including: silicone rubber dies, rollers, sheets, part holding fixtures and heat seal supplies.

### Trusted Partner for Your Product Decorating Needs

United Silicone 4471 Walden Avenue, Lancaster, NY 14086  
Tel +1 (716) 681 8222 Fax +1 (716) 681 8789  
Email [info@unitedsilicone.com](mailto:info@unitedsilicone.com)

[www.unitedsilicone.com](http://www.unitedsilicone.com) [www.itwids.com](http://www.itwids.com)

A MEMBER OF

 **IDS** | A Division of ITW

## Operating Features

An advanced control system specifically designed and optimized for heat transfer applications. The control unit provides reliability over all functions, has machine setting memory for temperature and time parameters and has the flexibility for expansion and customization. Side-mounted operator controls with touch screen display offer operator convenience displaying machine settings, status and diagnostic messages. Featured are digital controls of stamping temperature with overheat set-point protection, dwell time and accurate eye mark detection for transfer placement. Also provided are transfer "pull" delay and digital parts counter with reset as well as set-up and head-up delay selectors.

Fast, accurate head height coarse adjustment.

Vernier fine adjustment and positive stop on a double-acting pneumatic cylinder allows precise control of stroke length and accurate stamping force. The head guide system consisting of large diameter cylinder rods and guide shafts ensures stability throughout head travel.

Front panel head speed flow controls permit convenient adjustment of up and down head travel speeds, cycle times, stamping and foil stripping conditions.

Pre-drilled and tapped anodized aluminum work table provides a stable setup platform and convenient fixture mounting.

Precision web advance system driven by a stepper motor produces constant torque for smooth advance and reliable control

- Adjustable guides maintain accurate foil positioning in relation to decorating surface.
- Quick-release take-up shaft facilitates rapid roll changeover.

## Construction Features

Rugged, steel weldment frame provides high stamping repeatability. All machined components are coated for long-term protection. Coatings include paint, nickel plating, and anodizing. The machine is supplied with a rugged steel machine stand with soild top and leveling feet providing a sturdy mounting platform.

Specifications	
Maximum Stamping Force (Tons)	1
A- Head Stroke (Inches)	4" diameter x 6" Long
B- Work Table Height (Inches)	39-43
C- Working Height (Inches)	0-12
D- Throat Depth (Inches)	8
E- Approximate Dimensions (Height) (Inches)	44
F- Width	40
G- Depth (Inches)	30
Electrical Requirements (Volts)	220
Air Requirements (CFM)	3
Working Pressure (PSI)	10-100
Standard Dimensions (Inches)	30x30x30
Net Weight (Pounds)	800

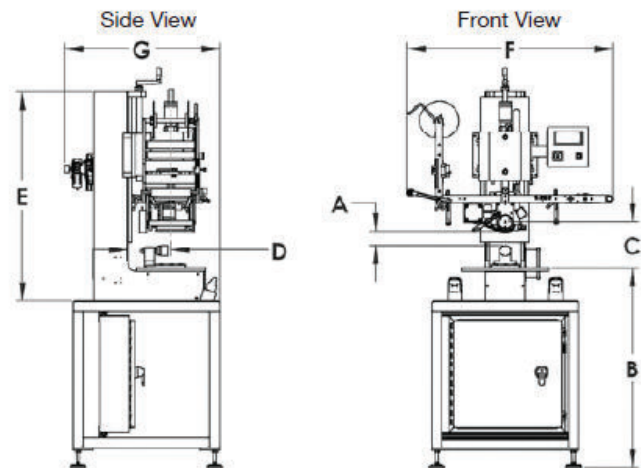

In keeping with its policy of continuous product improvement, United Silicone reserves the right to discontinue or change specifications, designs, materials and equipment without notice or obligation, consistent with sound engineering principles and modern practices.



### Trusted Partner for Your Product Decorating Needs

United Silicone 4471 Walden Avenue, Lancaster, NY 14086

Tel +1 (716) 681 8222 Fax +1 (716) 681 8789

Email [info@unitedsilicone.com](mailto:info@unitedsilicone.com)

[www.unitedsilicone.com](http://www.unitedsilicone.com) [www.itwids.com](http://www.itwids.com)

A MEMBER OF

 **IDS** | A Division of ITW

## Operating Features

An advanced control system specifically designed and optimized for heat transfer applications. The control unit provides reliability over all functions, has machine setting memory for temperature and time parameters and has the flexibility for expansion and customization. Side-mounted operator controls with touch screen display offer operator convenience displaying machine settings, status and diagnostic messages. Featured are digital controls of stamping temperature with overheat set-point protection, dwell time and accurate eye mark detection for transfer placement. Also provided are transfer “pull” delay and digital parts counter with reset as well as set-up and head-up delay selectors.

Fast, accurate head height coarse adjustment.

Vernier fine adjustment and positive stop on a double-acting pneumatic cylinder allows precise control of stroke length and accurate stamping force. The head guide system consisting of large diameter cylinder rods and guide shafts ensures stability throughout head travel.

Front panel head speed flow controls permit convenient adjustment of up and down head travel speeds, cycle times, stamping and foil stripping conditions.

Pre-drilled and tapped anodized aluminum work table provides a stable setup platform and convenient fixture mounting.

Precision web advance system driven by a stepper motor produces constant torque for smooth advance and reliable control

- Adjustable guides maintain accurate foil positioning in relation to decorating surface.
- Quick-release take-up shaft facilitates rapid roll changeover.

## Construction Features

Rugged, steel weldment frame provides high stamping repeatability. All machined components are coated for long-term protection. Coatings include paint, nickel plating, and anodizing. The machine is supplied with a rugged steel machine stand with soild top and leveling feet providing a sturdy mounting platform.

Specifications	
Maximum Stamping Force (Tons)	1
A- Head Stroke (Inches)	4" diameter x 6" Long
B- Work Table Height (Inches)	39-43
C- Working Height (Inches)	0-12
D- Throat Depth (Inches)	8
E- Approximate Dimensions (Height) (Inches)	44
F- Width	40
G- Depth (Inches)	30
Electrical Requirements (Volts)	220
Air Requirements (CFM)	3
Working Pressure (PSI)	10-100
Standard Dimensions (Inches)	30x30x30
Net Weight (Pounds)	800

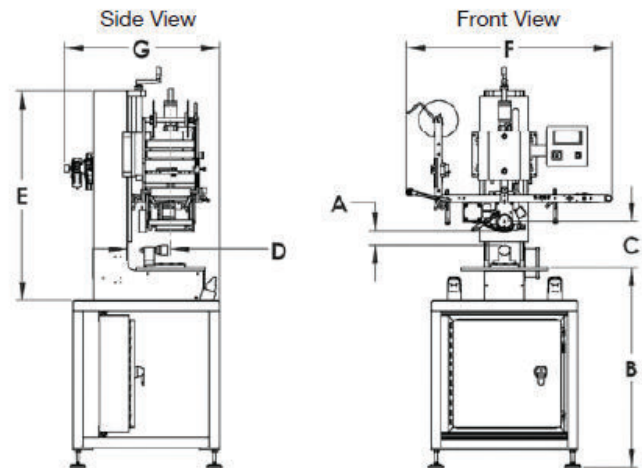

In keeping with its policy of continuous product improvement, United Silicone reserves the right to discontinue or change specifications, designs, materials and equipment without notice or obligation, consistent with sound engineering principles and modern practices.



### Trusted Partner for Your Product Decorating Needs

United Silicone 4471 Walden Avenue, Lancaster, NY 14086

Tel +1 (716) 681 8222 Fax +1 (716) 681 8789

Email [info@unitedsilicone.com](mailto:info@unitedsilicone.com)

[www.unitedsilicone.com](http://www.unitedsilicone.com) [www.itwids.com](http://www.itwids.com)

A MEMBER OF

