

Models US40, US75 & US120 Vertical Hot Stamp & Heat Transfer Equipment



United Silicone's large - area hot stamp and heat transfer decorating machines provide advanced capabilities for reduced setup time, high reliability, efficiency, smooth and quiet operation and simplified troubleshooting. These versatile machines may also be used for graphic foil stamping, die cutting, and embossing. All machines feature stable, consistent head travel and smooth foil advance for optimum stamping quality from job to job.

Advanced Control System

- Job storage capabilities
- Advanced diagnostic capabilities
- Digital control of temperature and time parameters
- Graphics screen on operator control interface

Powerful Stamping Force and Control

- Stamping force generated by the action of a camplified horizontal cylinder offering consistent, repeatable stamping pressure
- Front -panel fine adjustment offers precise control over head stroke length and stamping force
- Numerous head sizes to accommodate a wide range of part sizes

Precision Foil Advance

- Optional, adjustable head-up delay regulates cooling time for optimum foil release

Precision Heat Transfer Web Advance

- DC Motor with constant torque, electronic web offset adjustment

Customer Benefits:

- Constant torque for smooth advance
- Accurate, repeatable cycling for minimal transfer/foil waste
- Safe, quiet, smooth cycling
- Provides safe work environment

United Silicone, part of Industrial Decorating Solutions (IDS), specializes in the design and production of standard and custom hot stamp and heat transfer decorating machines. Our automation department offers complete capabilities from integrated applications to full turnkey systems.

United Silicone also provides a complete range of supplies including: silicone rubber dies, rollers, sheets, part holding fixtures and heat seal supplies.

	US 40	US 75	US 120
Maximum Stamping Force	4 Ton	7.5 Ton	12 Ton
Standard Head Size	12" x 16"	12" x 16"	12" x 16"

Trusted Partner for Your Product Decorating Needs

United Silicone 4471 Walden Avenue, Lancaster, NY 14086
 Tel +1 (716) 681 8222 Fax +1 (716) 681 8789
 Email info@unitedsilicone.com

www.unitedsilicone.com www.itwids.com

A MEMBER OF



Operating Features

An advanced control system is specifically designed and optimized for hot stamp and heat transfer applications. The control unit provides reliability over all functions, has machine setting memory for all temperatures and time parameters and has the flexibility for expansion and customization. Side-mounted operator controls with membrane switch panel and graphics screen display offers operator convenience by displaying machine settings, machine status and diagnostic messages. Featured is digital control of stamping temperature with overheat set point protection, dwell time, foil pull time and resistance to electro - magnetic interference. Also provided is a before/after foil pull selector, digital parts counter with reset, a set - up selector and optional head - up delay selector.

Consistent stamping pressure and stable head action resulting from the cam -amplified force of a horizontal cylinder and cam-follower travel guides.

Head height fine adjustment allows precise control of stroke length and stamping force.

Head angle adjustment permits proper front - to - rear angular relationship to be set between die and work table. Front panel head speed flow controls permit convenient adjustment of up and down head travel speeds, cycle time, stamping and foil stripping conditions.

Pre-drilled and tapped 16" x 24" steel work table provides a stable setup platform and convenient fixture mounting.

Adjustable work table outriggers provide independent work height adjustment and support at all four corners.

Dual palm buttons combine reliable cycle starting with operator safety.

Quick-change die holder with adjustable stops ensures positive, repeatable die positioning.

Construction Features

- Rugged steel machine frame for reliability and repeatability
 - Machine components, available painted, chrome plated, black oxide coated, and anodized providing long -term corrosion protection .
 - Machine base with solid top and leveling feet offers a sturdy base and independent leveling adjustment on all four corners.
- *Optional Auxiliaries – Electrical Eye Heat Transfer Indexer, Rotary Index Table, Slide Table, X -Y or X-Y-R Positioning Tables & Special Safety Guarding*

Specifications

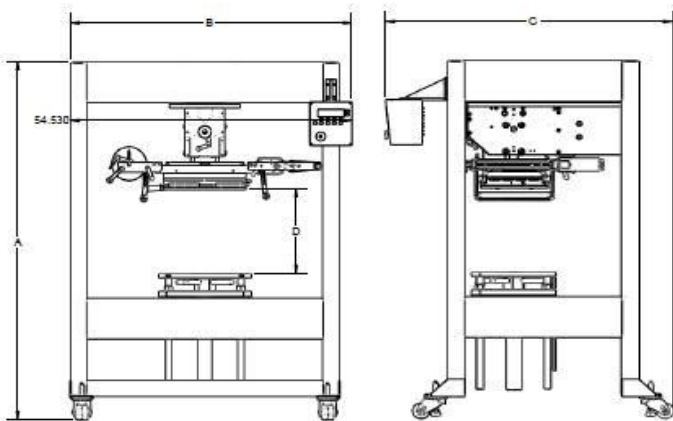

4-Post Frame	A	B	C	D
US40	72	54	51	2-14
US75	73	56	53	4-16
US120	75	56	53	4-16

*All sizes are referenced in Inches

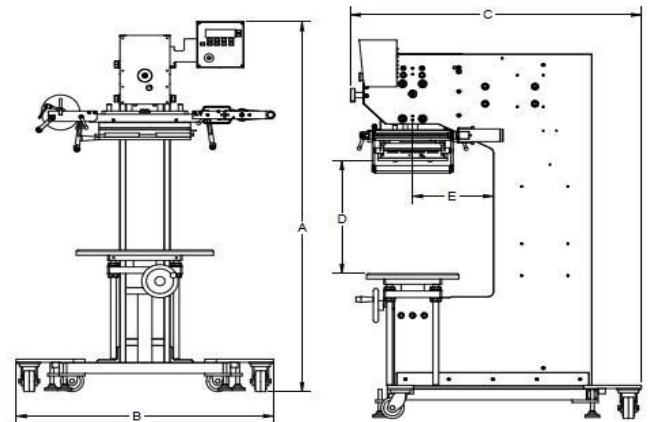

"C" Frame	A	B	C	D	E
US40	68.5	24	29	0-13.5	10
US75	72	45	43	3.5-18	12
US120	72	45	45	3.5-18	14

Trusted Partner for Your Product Decorating Needs

United Silicone 4471 Walden Avenue, Lancaster, NY 14086

Tel +1 (716) 681 8222 Fax +1 (716) 681 8789

Email info@unitedsilicone.com

www.unitedsilicone.com www.itwids.com

A MEMBER OF

