

Impact HT Roll - On Hot Stamp & Heat Transfer Equipment

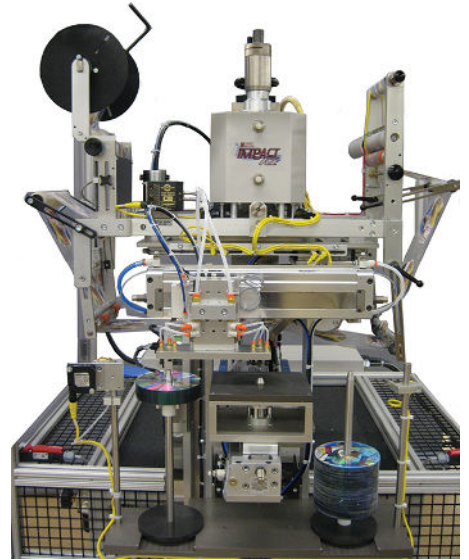

The Impact HT, designed and manufactured at United Silicone, uses a heated silicone roller to apply screen printed heat transfer decals and decorative foil to flat or slightly contoured surfaces.

Design Specifications

- Easily adjustable decoration speed to accommodate a wide variety of part sizes and decal chemistries.
- Up to 5" x 10" decorating area
- A variety of substrates including plastic, metal, painted surfaces, wood and paper can be decorated
- Easy to use frontmounted operator interface
- Accommodates silicone rubber rollers up to 4 inches in diameter, and from 1 to 6 inches long
- Designed to allow installation of custom material handling features
- Includes a one year warranty on parts and labor

Customer Benefits:

- Constant torque for smooth advance
- Accurate, repeatable cycling for minimal transfer/foil waste
- Safe, quiet, smooth cycling
- Provides safe work environment

United Silicone, part of Industrial Decorating Solutions (IDS), specializes in the design and production of standard and custom hot stamp and heat transfer decorating machines. Our automation department offers complete capabilities from integrated applications to full turnkey systems.

United Silicone also provides a complete range of supplies including: silicone rubber dies, rollers, sheets, part holding fixtures and heat seal supplies.

Trusted Partner for Your Product Decorating Needs

United Silicone 4471 Walden Avenue, Lancaster, NY 14086
Tel +1 (716) 681 8222 Fax +1 (716) 681 8789
Email info@unitedsilicone.com

www.unitedsilicone.com www.itwids.com

A MEMBER OF

 **IDS** | A Division of ITW

Operating Features

Belt driven carriage drive with variable speed DC motor guided by linear motion bearings for smooth advance and return with independent directional speed controls.

Articulating arm roller head assembly is powered by a vertical acting double acting main air cylinder with veneer-calibrated positive stop for precise, measured control of roll-on force and cylinder stroke length. Lever action permits even pressure distribution on contoured parts. The assembly features include a single-speed DC motor drive for roller rotation; stainless steel roller shroud and heater box cover; non-contact thermocouple; and quick-change roller mount.

WEBTRAK™ heat transfer indexer is versatile, accurate and reliable for registering heat transfer decals and can be switched to timed hot stamp foil feeding. A DC electric motor produces constant pulling torque for smooth advance and reliable control for efficient heat transfer or foil utilization. WEBTRAK™ features two-speed web advance system, micro-adjustable electric eye positioning, quick-release payout and take-up shafts.

Construction Features

Rugged, steel machine frame for roll-on reliability and repeatability with modular design for easy adaptation to oversize parts

Long term corrosion protection on machine components

Machine base with solid top and leveling feet offers a sturdy base and independent leveling adjustment on all four corners

*Optional Auxiliaries - Rotary Index Tables, Pneumatic Slide Tables, X-Y or X-Y-R Positioning Tables, Robot Interface, Light Curtain Safety Guarding, Custom Nest Tooling, Contoured Silicone Roller for slight radius parts

Specifications	
Roller Carriage Lateral Travel (Inches)	1-12
Head Stroke (Inches)	0-2
Roller Diameter (Inches)	4
Roller Length (Inches)	1-6
Approximate Dimensions Height (Inches)	75 High
Approximate Dimensions Width (Inches)	40 Wide
Approximate Dimensions Depth (Inches)	56 Deep
Electrical Requirements (Volts)	220 1 Phase
Air Requirements (CFM)	3
Air Requirements (PSI)	100
Net Weight (Pounds)	600

Safety Guarding Not Shown

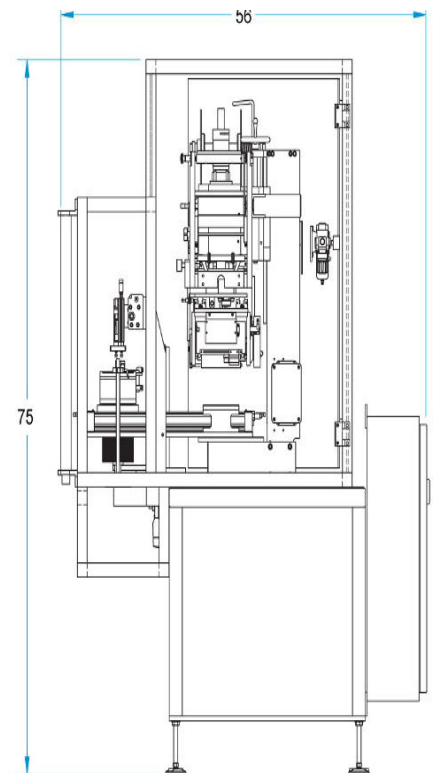
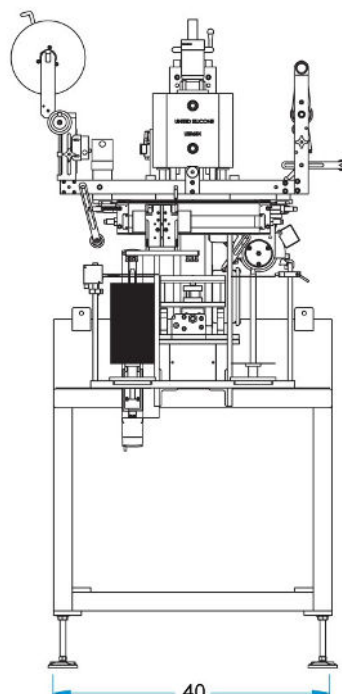

Trusted Partner for Your Product Decorating Needs

United Silicone 4471 Walden Avenue, Lancaster, NY 14086

Tel +1 (716) 681 8222 Fax +1 (716) 681 8789

Email info@unitedsilicone.com

www.unitedsilicone.com www.itwids.com

A MEMBER OF

IDS | A Division of ITW