



United Silicone's Evolution HT is designed specifically for high-speed applications of multi-color heat transfer decals up to 355°. Its unique design allows for adjustment to accommodate various bucket diameters, draft angles, and height.

### High -Speed Heat Transfer Applications

- Up to 12, 5 Gallon Pails/Minute
- 355° coverage

### Benefits of Heat Transfer Decals

- Chemical, moisture, and fade resistant
- Thermally bonds to the substrate
- Photographic replication
- Unlimited colors

### Construction Features

- Multiple adjustment points to accommodate range of container sizes
- Decorating head adjustment for draft angle modification
- Programmable stretch control of heat transfer
- Maintains consistent transfer tension
- Solid welded machine frame
- Allen Bradley Microprocessor
- Small footprint

### **Benefits:**

- Ability to decorate directly from the molding process
- Brilliant, multi-colored graphics provide "no label" look where decoration appears to be part of the container
- Pre-printed graphics allow for simple roll changeovers
- Easy to operate system means accurate, repeatable transfer placement

### **Eliminates:**

- Messy ink and solvent clean up
- Color registration & graphic alignment issues

**Trusted Partner for Your Product Decorating Needs**

United Silicone 4471 Walden Avenue, Lancaster, NY 14086

Tel +1 (716) 681 8222 Fax +1 (716) 681 8789

Email [info@unitedsilicone.com](mailto:info@unitedsilicone.com)

[www.unitedsilicone.com](http://www.unitedsilicone.com) [www.itwids.com](http://www.itwids.com)

A MEMBER OF

 **IDS** | A Division of ITW

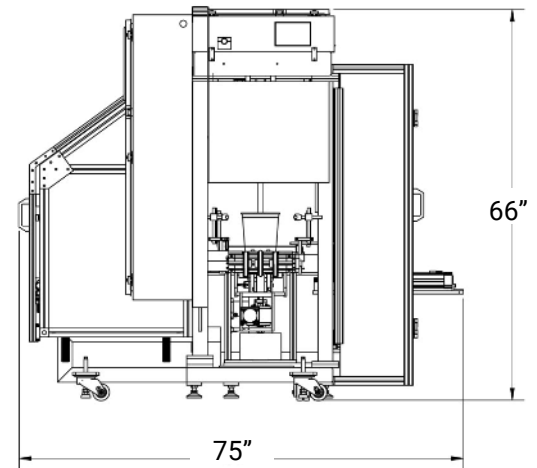
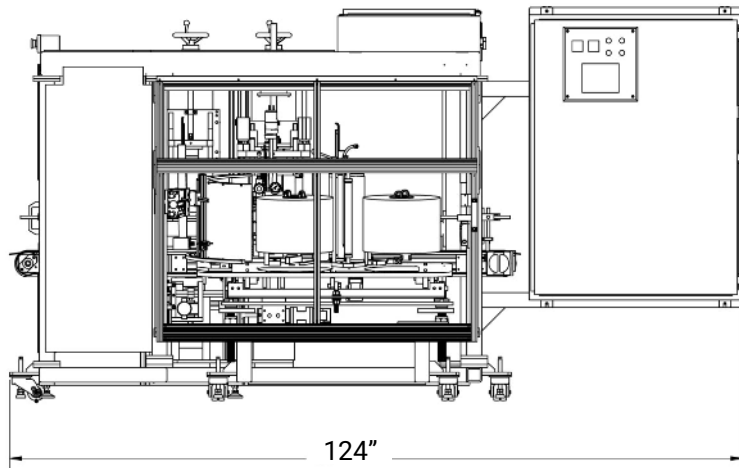

### Operating Features:

- Inline container @ 12 parts per minute
- Pre and post flame treatment
- Multiple configuration accommodating containers from 1-6 gallons

### System Requirements:

- Electrical: 480Volts, 3 Phase 15 AMP
- Pneumatic: 100 PSI moisture free air
- Natural gas or propane

### System Dimensions:

- Width: 124"
- Height: 66"
- Length: 75"

United Silicone, an ITW Decorating Company, specializes in the design and production of standard and custom hot stamp and heat transfer decorating machines. Our automation department offers complete capabilities from integrated applications to full turnkey systems.

United Silicone also provides a complete range of supplies including: silicone rubber dies, rollers, sheets, part holding fixtures and heat seal supplies.

As a leading designer and manufacturer of state-of-the-art plastics decorating systems, United Silicone has the in-house engineers to provide solutions to your toughest decorating problems.

### Trusted Partner for Your Product Decorating Needs

United Silicone 4471 Walden Avenue, Lancaster, NY 14086  
Tel +1 (716) 681 8222 Fax +1 (716) 681 8789  
Email [info@unitedsilicone.com](mailto:info@unitedsilicone.com)

[www.unitedsilicone.com](http://www.unitedsilicone.com) [www.itwids.com](http://www.itwids.com)

A MEMBER OF

