

2 UNITED SILICONE
EVOLUTION
 ht

United Silicone's Evolution ² is designed specifically for applying multi-color heat transfer decals up to 355° on both square and round pails. Its unique design allows for adjustment to accommodate various bucket diameters, draft angles and heights.

High-Speed Heat Transfer Applications

- Up to 8, 1-5 gallon containers per minute
- 355° coverage

Benefits of Heat Transfer Decals

- Chemical, moisture and fade resistant
- Thermally bonds to the substrate
- Photographic replication
- Unlimited colors

Construction Features

- Multiple adjustment points to accommodate range of container sizes
- Decorating head adjustment for draft angle modification
- Programmable stretch control of heat transfer
- Maintains consistent transfer tension
- Solid welded machine frame
- Allen Bradley Microprocessor
- Small footprint
- Pre and Post Flame Treatment

Benefits:

- Multi-Functional Equipment designed for square or round pail decoration
- Full 355 ° Wrap
- Easy to operate system means accurate, repeatable transfer placement
- Eliminates need to align images – all 4 panels are pre-printed on one roll
- Ability to decorate directly from the molding process
- Brilliant, multi-colored graphics provide “no label” look where decoration appears to be part of the container

Eliminates:

- Messy ink and solvent clean up
- Color registration & graphic alignment issues

Trusted Partner for Your Product Decorating Needs

United Silicone 4471 Walden Avenue, Lancaster, NY 14086

Tel +1 (716) 681 8222 Fax +1 (716) 681 8789

Email info@unitedsilicone.com

www.unitedsilicone.com www.itwids.com

A MEMBER OF

 **IDS** | A Division of ITW

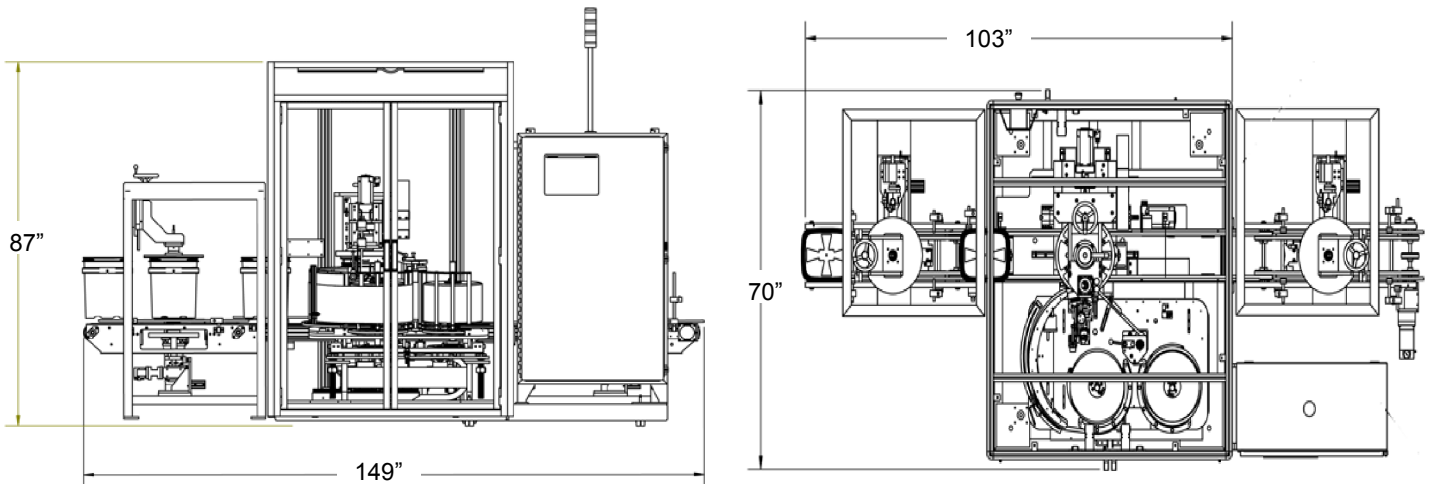

Operating Features:

- Inline container @ up to 8 parts per minute
- Pre and post flame treatment
- Multiple configuration accommodating containers from 1-5 gallons

System Requirements:

- Electrical: 480Volts, 3 Phase 30AMP
- Pneumatic: 100 PSI moisture free air
- Natural gas or propane

System Dimensions:

- Width: 70"
- Height: 87"
- Length: 149"

United Silicone, an ITW Decorating Company, specializes in the design and production of standard and custom hot stamp and heat transfer decorating machines. Our automation department offers complete capabilities from integrated applications to full turnkey systems.

United Silicone also provides a complete range of supplies including: silicone rubber dies, rollers, sheets, part holding fixtures and heat seal supplies.

As a leading designer and manufacturer of state-of-the-art plastics decorating systems, United Silicone has the in-house engineers to provide solutions to your toughest decorating problems.

Trusted Partner for Your Product Decorating Needs

United Silicone 4471 Walden Avenue, Lancaster, NY 14086
 Tel +1 (716) 681 8222 Fax +1 (716) 681 8789
 Email info@unitedsilicone.com

www.unitedsilicone.com www.itwids.com

A MEMBER OF

 **IDS** | A Division of ITW