



United Silicone's Evolution HT – Grower's Edition is designed specifically for nursery containers requiring high - speed applications of multi-color heat transfer decals up to 355 degrees. This new design temporarily seals off drainage holes, creating a sealed chamber to allow for optimal heat transfers. This system provides adjustments to accommodate various nursery container diameters, draft angles and heights.

High-Speed Heat Transfer Applications

- Up to 10, 1 -4 gallon containers per minute
- 355° coverage
- Inflation device temporarily seals off drainage holes, creating a sealed chamber ensuring optimal heat transfer decoration

Benefits of Heat Transfer Decals

- Chemical, moisture, and fade resistant
- Thermally bonds to the substrate
- Photographic replication
- Unlimited colors

Construction Features

- Multiple adjustment points to accommodate range of container sizes
- Decorating head adjustment for draft angle modification
- Programmable stretch control of heat transfer
- Maintains consistent transfer tension
- Solid welded machine frame
- Allen Bradley Microprocessor
- Small footprint

Benefits:

- Shown to increase productivity by 15 -20%
- Ability to decorate directly from the molding process
- Brilliant, multi -colored graphics provide "no label" look where decoration appears to be part of the container
- Pre-printed graphics allow for simple roll change overs
- Easy to operate system means accurate, repeatable transfer placement

Eliminates:

- Messy ink and solvent clean up
- Color registration & graphic alignment issues

Trusted Partner for Your Product Decorating Needs

United Silicone 4471 Walden Avenue, Lancaster, NY 14086
 Tel +1 (716) 681 8222 Fax +1 (716) 681 8789
 Email info@unitedsilicone.com

www.unitedsilicone.com www.itwids.com

A MEMBER OF

 **IDS** | A Division of ITW

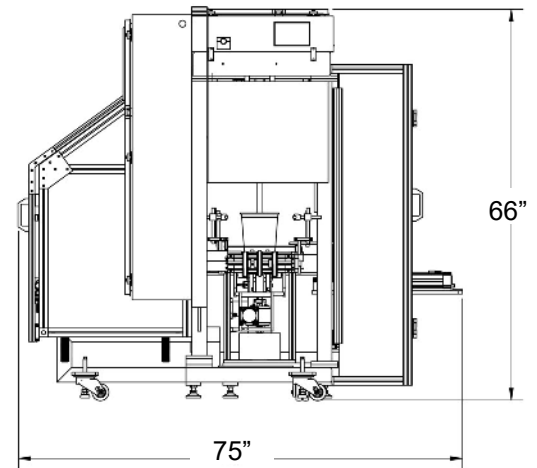
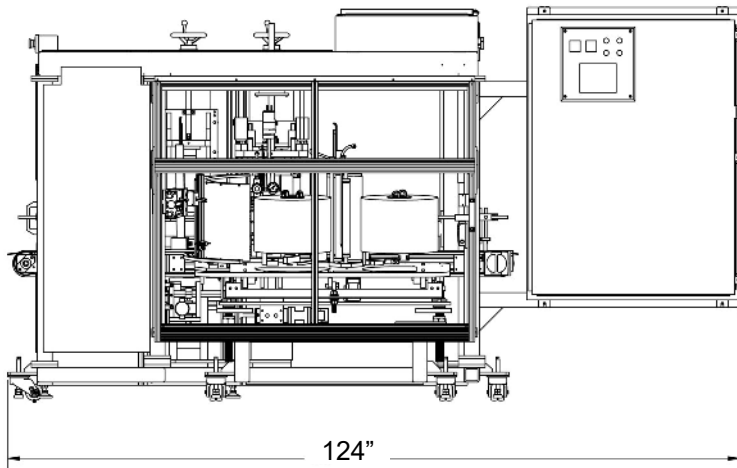

Operating Features:

- Inline container at 10 parts per minute
- Pre and post flame treatment
- Multiple configurations accommodating containers from 1-5 gallons

System Requirements:

- Electrical: 480 Volts, 3 Phase 15 AMP
- Pneumatic: 100 PSI moisture free air
- Natural gas or propane

System Dimensions:

- Width: 124"
- Height: 66"
- Length: 75"

United Silicone, an ITW Decorating Company, specializes in the design and production of standard and custom hot stamp and heat transfer decorating machines. Our automation department offers complete capabilities from integrated applications to full turnkey systems.

United Silicone also provides a complete range of supplies including: silicone rubber dies, rollers, sheets, part holding fixtures and heat seal supplies.

As a leading designer and manufacturer of state-of-the-art plastics decorating systems, United Silicone has the in-house engineers to provide solutions to your toughest decorating problems.

Trusted Partner for Your Product Decorating Needs

United Silicone 4471 Walden Avenue, Lancaster, NY 14086

Tel +1 (716) 681 8222 Fax +1 (716) 681 8789

Email info@unitedsilicone.com

www.unitedsilicone.com www.itwids.com

A MEMBER OF

