



United Silicone's Cyclone HT High Speed Heat Transfer Application System applies full color heat transfer labels to round and single side oval injection/blow molded containers. The Cyclone's servo driven application technology coupled with a continuous rotary turret system allows for maximum decorating performance. Various container heights and diameters can be decorated. Photographic quality Therimage heat transfer labels in roll format allow for simple graphic changeover. Consistent decoration container to container can be achieved with the system's precise electronic label positioning features.

High-Speed Heat Transfer Applications

- Rounds, Up to 120 Containers/Minute Full Coverage
- Single Side Ovals, 250+ Containers/Minute
- Continuous Motion Decorating
- *Speed dependent on container size and label length

Benefits of Heat Transfer Decals

- Brilliant, Multicolored Graphics – Provide “no label look” on containers
- Gravure Printed Quality
- Photographic Resolution
- Pearlescent and Frosted Effects
- Permanent, Safe Decoration- Dry Process (No Wet Inks)
- Chemical and moisture resistant
- Passes Oral Toxicity Test
- Labels Recyclable with Containers

Construction Features

- Allen Bradley Microprocessor with VPN Modern Interface
- Easy to use Touch Screen
- Modular Decorating Head Platform
- Single Head Servo Controlled with Angle Adjustment
- Turret Re-tooling Capabilities: For Various Container Sizes

Cyclone HT Benefits:

Container Shape:

- Rounds
- Single Side Ovals

Container Sizes:

- Diameters of 1.5” to 6.75”

Container Type:

- HDPE
- PET
- PP & Similar Materials
- Blow Molded
- Injection Molded

Label Sizes:

- Up to 18” L x 8” H

Label Type:

- Runs No -Flame
- Runs Flame Label

Label Style:

- Roll Format: Up to 7 Color Artwork

Trusted Partner for Your Product Decorating Needs

United Silicone 4471 Walden Avenue, Lancaster, NY 14086

Tel +1 (716) 681 8222 Fax +1 (716) 681 8789

Email info@unitedsilicone.com

www.unitedsilicone.com www.itwids.com

A MEMBER OF

 **IDS** | A Division of ITW

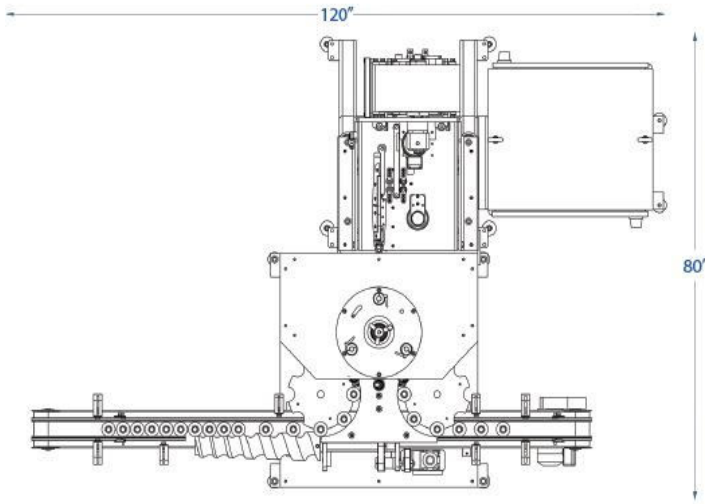

TOP VIEW

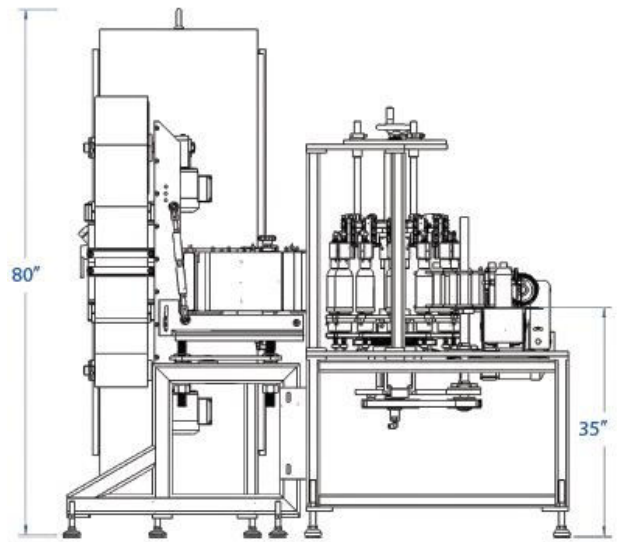

SIDE VIEW



Cyclone HT Features:

- Treatment Options: Pre-and post-flame treatment
- Orientation Capabilities: Containers located for precise decoration
- Tolerances of Label Placement:
 - Approx. +/- 1/16th of an inch
 - Graphic stretch capabilities: Label adjustment for container inconsistencies
- Flexibility: In-line capabilities: at molder, filler or both

System Requirements:

- Electrical: 220 Volts, 3 Phase, 60 AMP
- Pneumatic: 100 PSI moisture free air, 5 CFM
- Cooling fluid required

United Silicone, part of Industrial Decorating Solutions (IDS), specializes in the design and production of standard and custom hot stamp and heat transfer decorating machines. Our automation department offers complete capabilities from integrated applications to full turnkey systems.

United Silicone also provides a complete range of supplies including: silicone rubber dies, rollers, sheets, part holding fixtures and heat seal supplies.

As a leading designer and manufacturer of state-of-the-art plastics decorating systems, United Silicone has the in-house engineers to provide solutions to your toughest decorating problems.

Trusted Partner for Your Product Decorating Needs

United Silicone 4471 Walden Avenue, Lancaster, NY 14086
Tel +1 (716) 681 8222 Fax +1 (716) 681 8789
Email info@unitedsilicone.com

www.unitedsilicone.com www.itwids.com

A MEMBER OF

 **IDS** | A Division of ITW